

SFS.

cleaning polishing passivation marking

WELDBRUSH 700

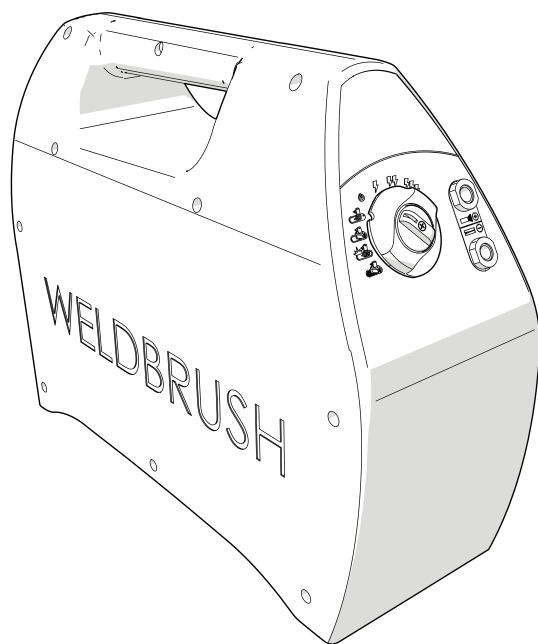

USER MANUAL



INTRODUCTION

Thank you for purchasing the WELDBRUSH 700. This user guide contains all the necessary information to quickly become familiar with the product. We kindly request that you read this information carefully before working with the WELDBRUSH 700.

This user guide is meant for the end-user of the WELDBRUSH 700. We trust this device will give you many years of good service. Printing, in whole or in part, is only allowed with prior consent of Stainless Finishing Solutions. Errors and omissions excepted. All rights reserved.

This is the original user guide. Store this manual in a safe place!

For any questions or to order manuals, please contact:

Stainless Finishing Solutions

39 Barnard Road,
Norwich,
NR5 9JB
United Kingdom





T +44 (0) 1603 263128
sales@stainlessfinishingsolutions.com

TABLE OF CONTENTS

1	Used symbols in the manual	4
2	General product description	4
2.1	Intended use	4
2.2	Functions of the WELDBRUSH 700.....	5
2.3	Main parts	6
2.4	Function of the LEDs.....	8
2.5	Symbols on the front panel	8
3	User group	9
4	Technical specifications	9
5	Precautions and safety warnings	9
6	Operation.....	11
6.1	Preparation	11
6.2	Cleaning & Passivation.....	14
6.3	Marking.....	22
6.4	Electro-polish	29
6.5	Electro-plating.....	37
7	After operation.....	43
8	Maintenance	43
9	Environment and Disposal	44
10	Trouble shooting.....	45
11	Warranty information	46
12	EC - declaration of conformity	47

1 USED SYMBOLS IN THE MANUAL

Note the use of the signal words DANGER, WARNING and CAUTION with the safety messages. The signal word for each message uses the following guidelines:

 DANGER	Indicates an imminently hazardous situation that, if not avoided, will result in death or serious injury.
 WARNING	Indicates a potentially hazardous situation that, if not avoided, could result in death or serious injury, and includes hazards that are exposed when guards are removed.
 CAUTION	Indicates a potentially hazardous situation that, if not avoided, may result in minor or moderate injury or product or property damage.
 NOTICE	This shows extra information that may help the reader.

2 GENERAL PRODUCT DESCRIPTION

2.1 INTENDED USE

The WELDBRUSH 700 is a weld cleaner intended to clean & passivate, electro-polish, mark or electro-plate stainless steel and some other non-ferrous materials. The WELDBRUSH 700 is only intended for professional and industrial use. Only use the WELDBRUSH 700 in a work environment which is free from other electrical devices or objects that could interfere with the ability to operate the WELDBRUSH 700 surface finishing system freely. The work environment needs to be well ventilated and completely separate from any combustible substances.

Any other form of use than what is described above does not constitute as intended use. Stainless Finishing Solutions cannot be held responsible for any injury or damage caused by the system being used incorrectly, unwisely or contrary to the intended use or used with non-genuine parts, fluids or accessories.

2.2 FUNCTIONS OF THE WELDBRUSH 700



Cleaning & Passivation



Marking



Electro-polishing



Electro-plating

Cleaning & Passivation

This mode will clean and passivate the metal surface. It uses the interaction between an electric current and a conductive fluid to remove heat marks, surface contamination and other non-physical surface imperfections from stainless steel and some other non-ferrous materials. Its proprietary, conductive brush applies cleaning fluid to the work surface, producing an electro-chemical cleaning action with astoundingly fast and effective results.

Marking

Marking leaves a permanent design on a metal surface with the use of a stencil. This process uses oxidation on the metal surface and does not apply color particles. The mark is permanent and forgery-proof.

Electro-polishing

This mode will produce a bright metal surface. Previously cleaned welds can be polished or the gloss level adjusted to the surrounding surface as required. Matt areas after cleaning on either side of the weld is a result of chromium depletion during the welding process, these can be removed with this mode. Because this process removes iron but not the other components of stainless steel, electro-polishing vastly improves the corrosion resistance of the surface of the stainless steel.

Electro-plating

Electro-plating is a surface covering in which a metal is deposited on a conductive surface and is used to decorate objects, for corrosion inhibition, to improve solderability, to harden, to improve wearability, to reduce friction, to improve paint adhesion, to alter conductivity, to improve IR reflectivity, for radiation shielding, and for other purposes.

2.3 MAIN PARTS

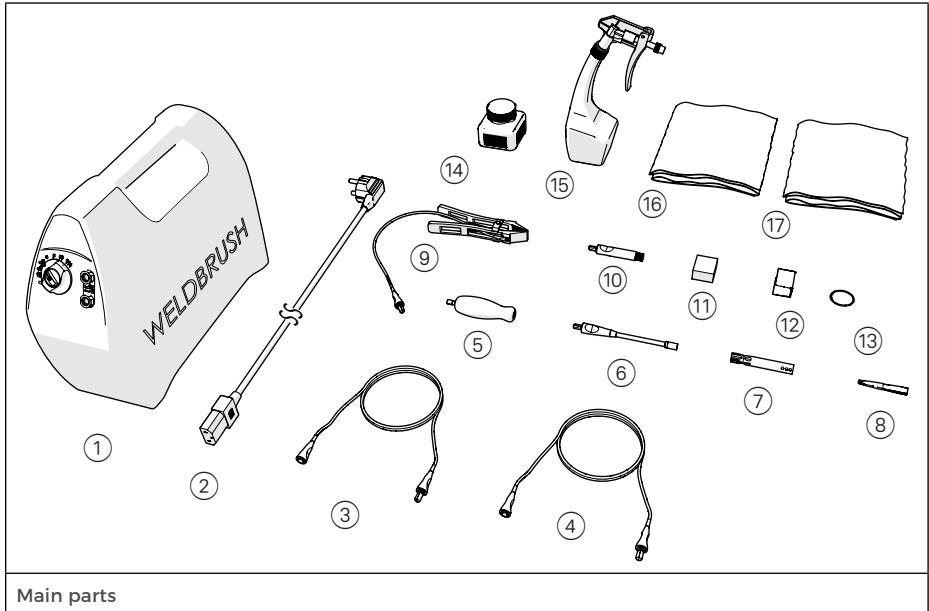

- | | | | |
|---|--------------------|----|--------------------|
| 1 | WELDBRUSH 700 unit | 9 | Earth clamp |
| 2 | Mains power cable | 10 | Electrode adapter |
| 3 | Red cable | 11 | Electrode |
| 4 | Black cable | 12 | Felt |
| 5 | Handle | 13 | O-ring |
| 6 | Wand | 14 | Fluid container |
| 7 | Sliding shroud | 15 | Spray bottle |
| 8 | Carbon fiber brush | 16 | Cleaning cloth |
| | | 17 | Neutralizing cloth |

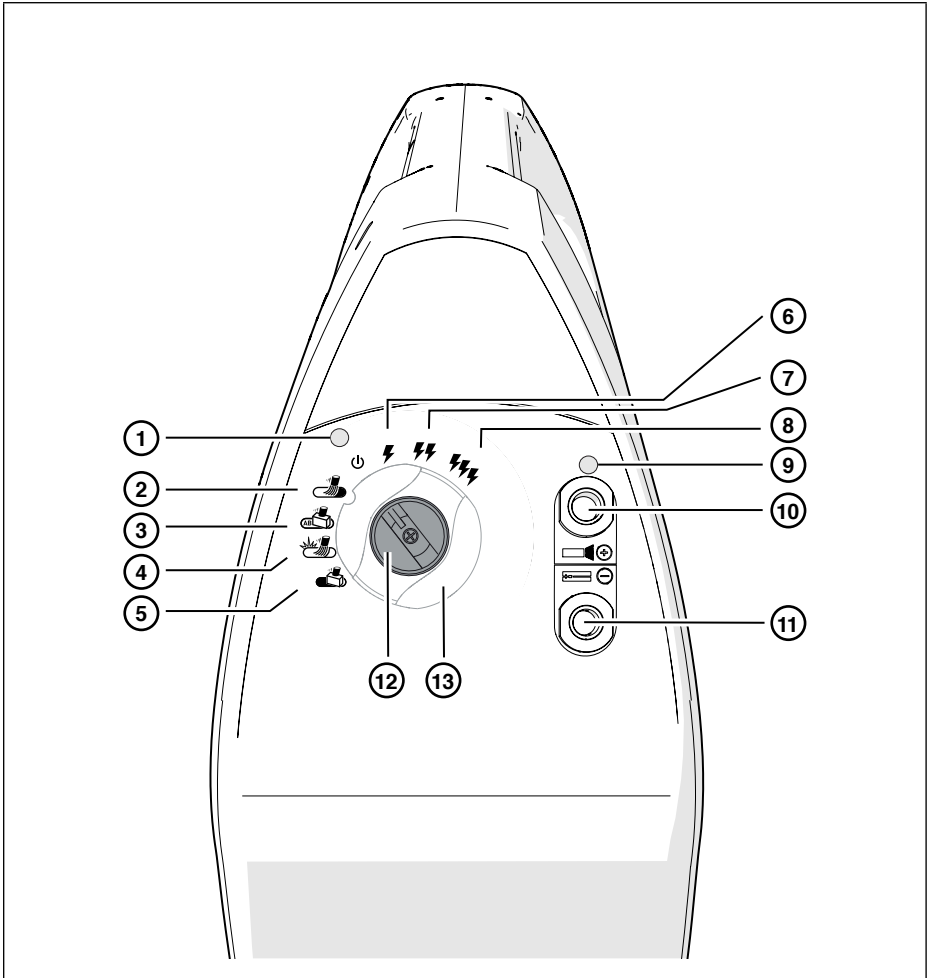

User-interface

- | | |
|--------------------------------------|------------------------------------|
| 1 Indication LED | 8 Power level 3 |
| 2 Cleaning & Passivation mode | 9 Power moderator LED |
| 3 Marking mode | 10 Red cable socket |
| 4 Electro-polishing mode | 11 Black earth clamp socket |
| 5 Electro-plating mode | 12 Power setting switch |
| 6 Power level 1 | 13 Mode setting switch |
| 7 Power level 2 | |

2.4 FUNCTION OF THE LEDS

Indication LED (1)

LED color	
None	No main power supply
Red	Main power is supplied, the power setting switch is in standby position
Green	Power level 1, 2 or 3 is applicable

Power moderator LED (9)

This LED will flash Red, when the Power moderator circuitry is turned on, and is under heavy load conditions. Optimal power delivery occurs when this LED flashes on, intermittently, once every few seconds, typically.

2.5 SYMBOLS ON THE FRONT PANEL

Mode symbols



Cleaning & Passivation



Marking



Electro-polishing



Electro-plating

Power level symbols



Stand-by



Power level 1



Power level 2



Power level 3

3 USER GROUP

The WELDBRUSH 700 may only be operated by professionals. Operation, maintenance and inspection may only be carried out by authorized and qualified specialists. The minimum age of the operator is 18. Authorized specialists are understood to be specialists trained by the user, the manufacturer or the service partner.

4 TECHNICAL SPECIFICATIONS

Product name:	WELDBRUSH 700
Input power supply:	Nom 230V/3A/47-63Hz
Output power supply:	Nom 14.5Vrms/20V DC/71Arms peak
Weight:	7.1Kg (WELDBRUSH 700 unit)
Dimensions:	32.5 x 11.5 x 26.5cm (l x b x h)
Degree of protection:	IP65
Duty cycle:	100%

5 PRECAUTIONS AND SAFETY WARNINGS

Personal safety and the safety of other personnel will be ensured by reading, understanding and following / implementing all safe working procedures, suggestions and precautions.

Failure to comply with this manual could result in permanent injury and or damage to the operator, other personnel, the device, the work piece or surrounding property and void the warranty.

Before operation

WARNING

- *Prior to use, be sure to set up a safe work environment free from other electrical devices or objects that could interfere with the ability to operate the WELDBRUSH 700 freely. This includes but is not limited to, a well ventilated area completely separate from any combustible substances. Also ensure that the work piece is not earthed or connected to any other welding or electrical device.*

- *Ensure that you have the recommended personal protection equipment (PPE) to use with the WELDBRUSH 700 and the fluids. Refer to the Material Safety Data Sheet (MSDS) for the specific requirement, relating to the fluid being used with the WELDBRUSH 700. All warnings, instructions and recommendations must be strictly adhered to.*
- *Prior to each use check the WELDBRUSH 700 and all parts for damage and wear. In case of extended use of the device in a damaged or worn state, permanent damage to the WELDBRUSH 700 and to the work piece may be caused. The electrical currents involved may also cause intense heating of the shorted or damaged part, which could result in burns to the operator.*
- *Ensure the WELDBRUSH 700 and all parts are clean and dry.*
- *Ensure that the WELDBRUSH 700 is located where it cannot easily fall and cause injury.*
- *Ensure that the cables do not present a trip hazard.*
- *The WELDBRUSH 700 must be switched off or in the standby mode before connecting the cables and when changing the handle, brush, electrode or felt.*
- *In order to avoid stray currents and their effects, the earth clamp must be connected directly to the workpiece or a part connected to the workpiece.*
- *Irrespective of whether the WELDBRUSH 700 is turned off at the rear, or in standby mode, electronic components are still connected to the outputs and if a welding or electrical device can in any way drive electrical power into the WELDBRUSH 700 outputs, this can cause irreparable damage to the WELDBRUSH 700.*
- *The WELDBRUSH 700 must not be turned 'ON' and 'OFF' in a quick succession.*

During operation

WARNING

- *The carbon fiber brush and its surrounding parts get very hot during extended use, be very careful not to touch these parts. Nor place these near any flammable materials.*
- *Fluids may vaporize during operation, these vapors should not be inhaled. The advised PPE or air extraction should be used. Provide fresh air circulation in your work place.*

- *Never place the brush, wand or electrode on the workpiece or workbench as this will cause contact with the surface where electrical current will continue to flow and can cause damage or constitute a hazard.*
- *Electromagnetic fields can also influence pacemakers. Users of these should not work with the device.*
- *In the events of accidents, the cleaning device must immediately be disconnected from the mains supply.*
- *Make sure the mains voltage is the same as is specified on the unit.*
- *Do not use the WELDBRUSH 700 for any other purpose or in a different way other than described in this manual.*

CAUTION

- *Only approved fluids should be used with the WELDBRUSH 700. Select the appropriate fluid for the process chosen.*
- *Always read the instructions of the fluid to prevent damages to the WELDBRUSH 700.*
- *Fluids used with the WELDBRUSH 700 can leave stains on concrete floors, clothing and other surfaces.*

After operating

WARNING

- *When cleaning the WELDBRUSH 700, ensure that the power is off at the rear, or the unit is in standby mode.*

6 OPERATION

6.1 PREPARATION

WARNING

- *Ensure the unit and all contact points are clean and dry, and the cables and connectors are undamaged and in good working order.*
- *Ensure that all O-rings on the connectors are present, clean and undamaged.*
- *The device must be switched off or in standby mode before connecting the cables and when changing the handle, brush, electrode or felt.*

► **Follow these instructions:**

- Connect the mains power cable from the WELDBRUSH 700 unit into a nominal mains power outlet.

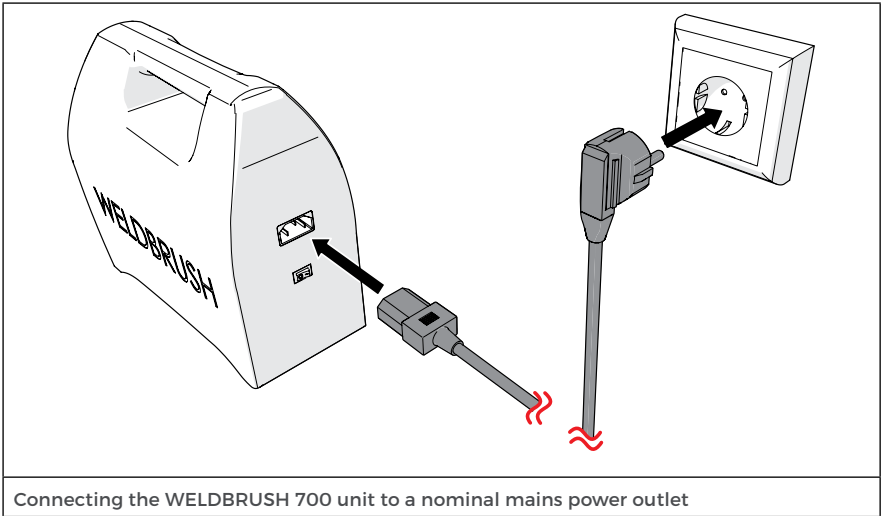

- Connect the red cable to the red cable socket on the WELDBRUSH 700 unit. Push in firmly, and rotate clockwise until fastened.

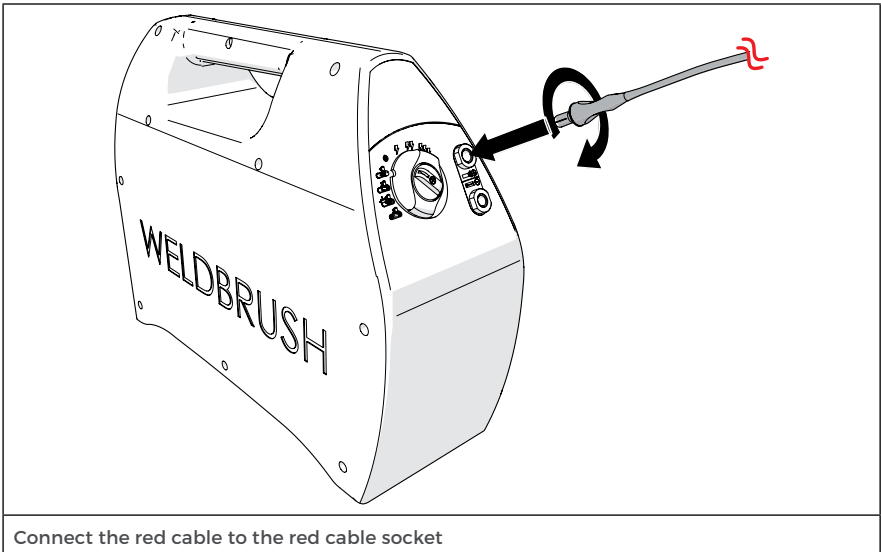

- Connect the black cable to the black earth clamp socket on the WELDBRUSH 700 unit. Push in firmly, and rotate clockwise until fastened.

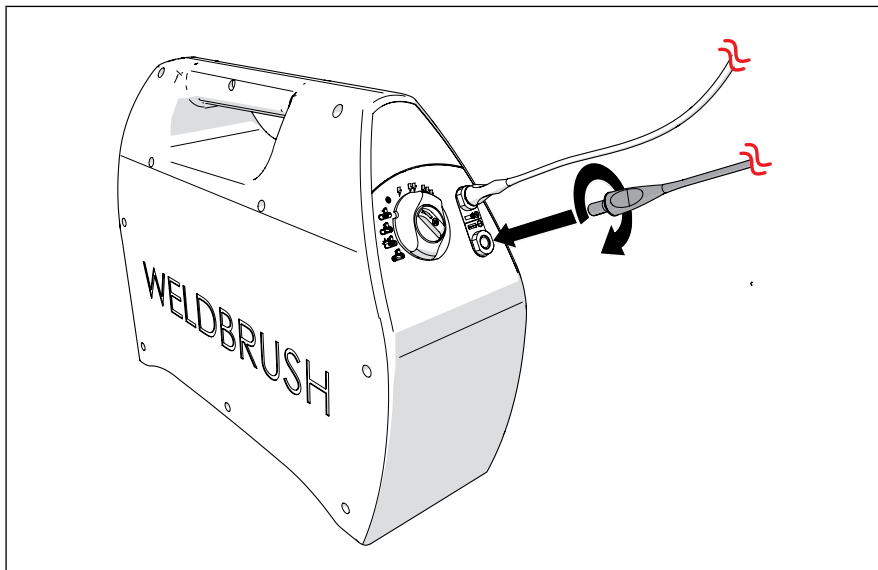

Connect the black cable to the black earth clamp socket

- Connect the earth clamp to the black cable. Push in firmly, and rotate clockwise until fastened.

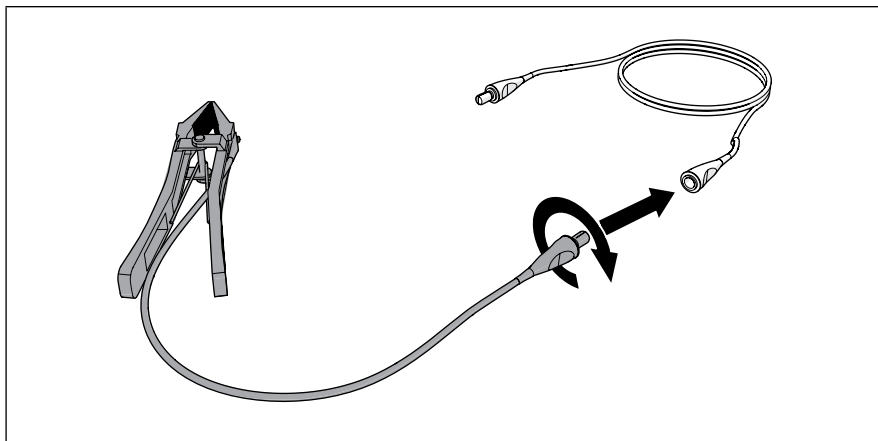

Connect the earth clamp to the black cable

You are now ready to treat the surface of the workpiece.

- To clean & passivate, refer to paragraph 6.2.
- To mark, refer to paragraph 6.3.
- To electro-polish, refer to paragraph 6.4.
- To electro-plate, refer to paragraph 6.5

6.2 CLEANING & PASSIVATION

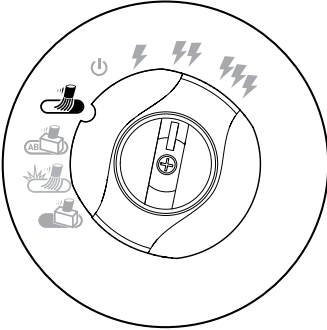

This mode will clean and passivate the metal surface. It uses the interaction between an electric current and a conductive fluid to remove heat marks, surface contamination and other non-physical surface imperfections from stainless steel and some other non-ferrous materials. Its proprietary, conductive brush applies cleaning fluid to the work surface, producing an electro-chemical cleaning action with astoundingly fast and effective results.

► **Follow these instructions:**

- Pour cleaning fluid into the fluid container.
- Wet the cleaning cloth with water and wring out sufficiently.
- Fill the spray bottle with neutralizing fluid.

- Connect the handle to the red cable. Push in firmly, and rotate clockwise until fastened.

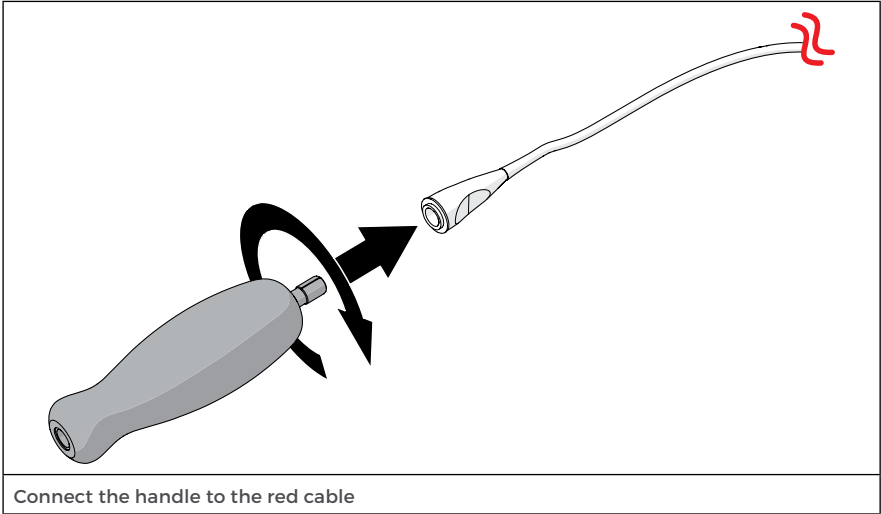

- Ensure the insulation on the wand is undamaged and in good condition.
- Connect the wand to the handle. Push in firmly, and rotate clockwise until fastened.

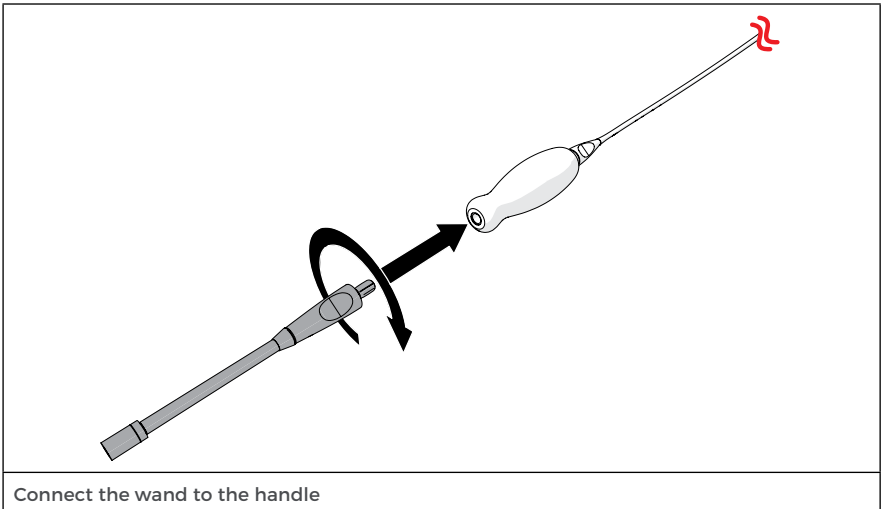

- Place the sliding shroud over the wand.

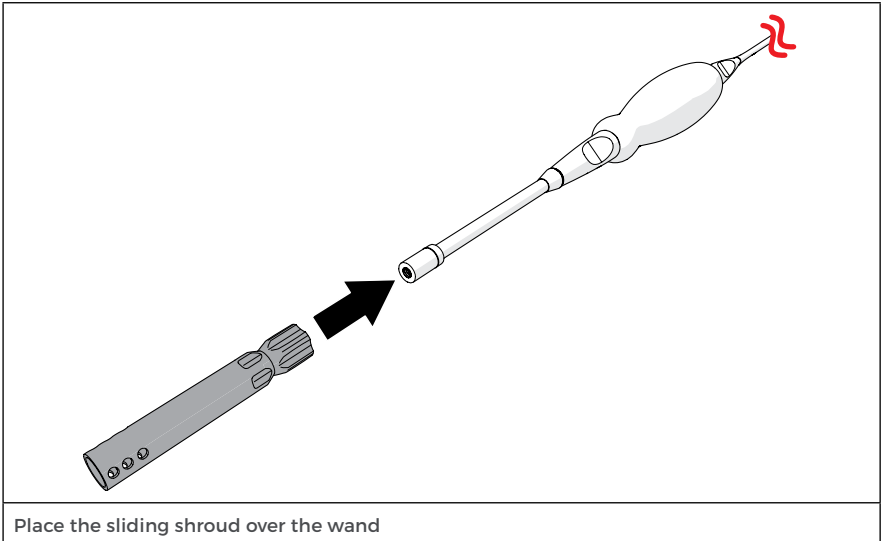

- Connect the brush to the wand. Turn clockwise until thread is fastened. Use a little copper fat in order to improve the electrical conductivity and protect the connection / thread from the fluids and avoid ceasing.

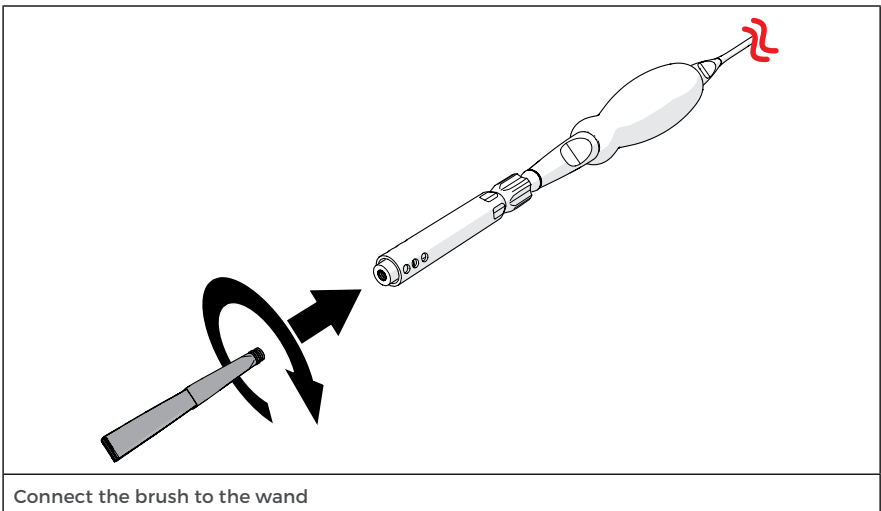

- Slide down the sliding shroud which will concentrate the brush fibers. This increases the cleaning power over a smaller area. It will also cause the fibers to penetrate into pores and pits in the surface as small as 20 - 30 micron wide.
- When you slide up the sliding shroud, the brush fibers will spread. This will allow you to cover a wider area.

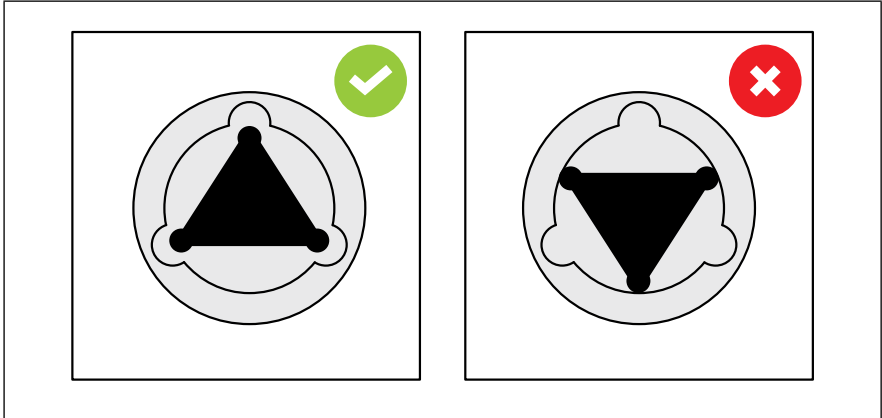

Do not miss align the sliding shroud with the brush shell

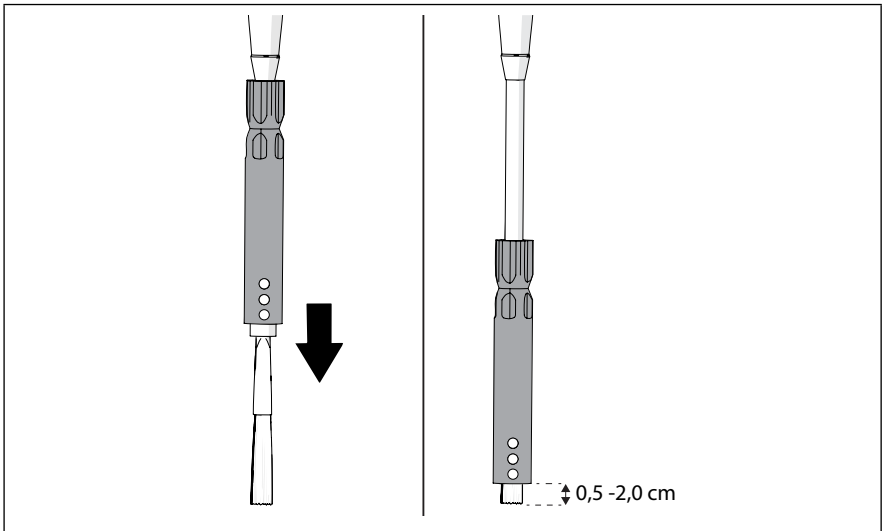

Slide the sliding shroud up and down to spread or concentrate the brush fibers

- Attach the earth clamp to a clean and dry area of the metal surface of the workpiece. If needed, remove any rust, paint, scale or other impurities.

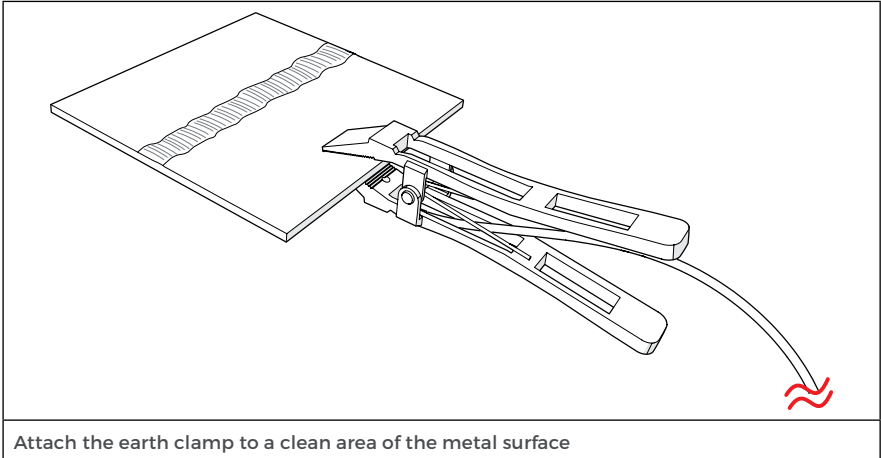

- Switch the WELDRUSH 700 unit from “0” to “1”. This switch is located at the rear of the WELDRUSH 700 unit.
- Select the cleaning & passivation mode by turning the mode setting switch.

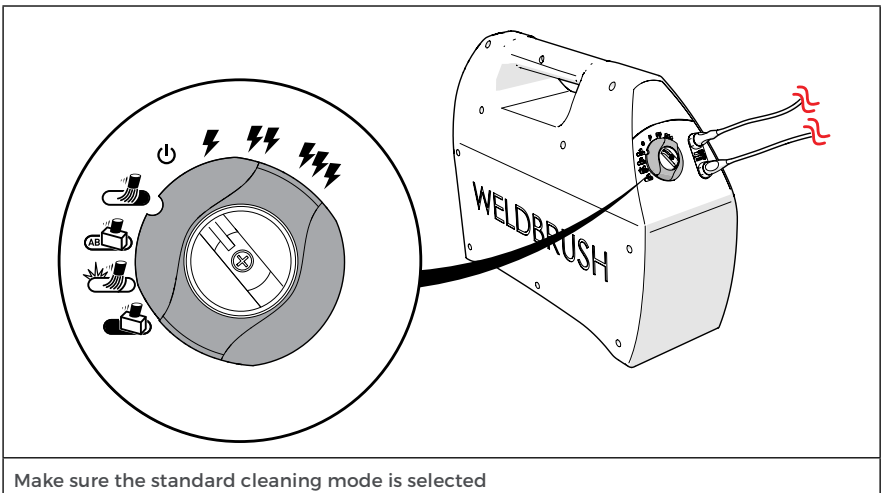

- Select the power level by turning the power setting switch. Power level 1 is the lowest power setting and power level 3 is the highest power level setting.

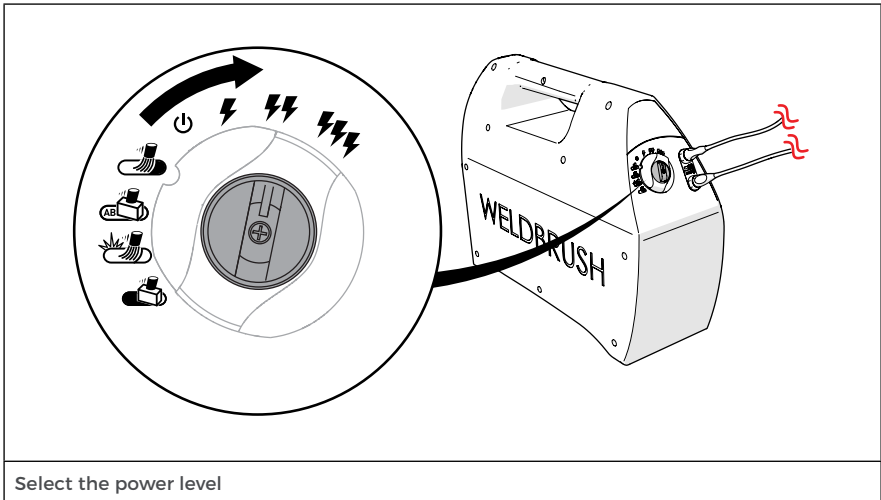

► **Read the following warnings and tips before you start cleaning & passivating:**

⚠ CAUTION

- *Be careful when cleaning & passivating welds and surfaces that are hot, this can cause damage or excessive wear to the brush and fluid.*
- *Do not keep the brush on the same place for too long, this causes the surface to get very hot and may cause surface damage or burn marks and excessive wear to the brush and fluid.*
- *If the WELDRUSH 700 is not operating correctly, please refer to the trouble shooting guide before contacting the WELDRUSH 700 manufacturer or distributor*
- *Do not slide the sliding shroud back far enough that it exposes the shell of the brush, this could make contact and cause damage to the workpiece as well as cause damage to the WELDRUSH 700.*

NOTICE

- Apply only sufficient pressure on the brush that the power moderator LED flashes only occasionally.
- By reducing or adding pressure to the brush, the operator can control optimal cleaning power.
- The brush will wear down with use and needs replacing before it reaches the shell of the brush.
- Black marks as a result of excessive temperature during welding or due to lack of gas during welding can usually not be removed completely as these oxides are no longer metallic and electrically conductive.
- Matte areas after cleaning on either side of the weld result from chromium depletion from the welding process, these can be removed with the electro-polish mode (refer to paragraph 6.4.)

► Now to start cleaning & passivating:

- Dip the full length of the fibers of the brush into the cleaning fluid so that these are fully saturated, and allow the excess fluid to drip off before removing it from the fluid container.

NOTICE

- The holes on the side of the shroud allow fluid to soak into the brush even when the shroud is covering the length of the brush.
- With your other hand, hold the damp cleaning cloth.
- Brush the tip lightly and evenly along the weld or heat mark in a circular movement.

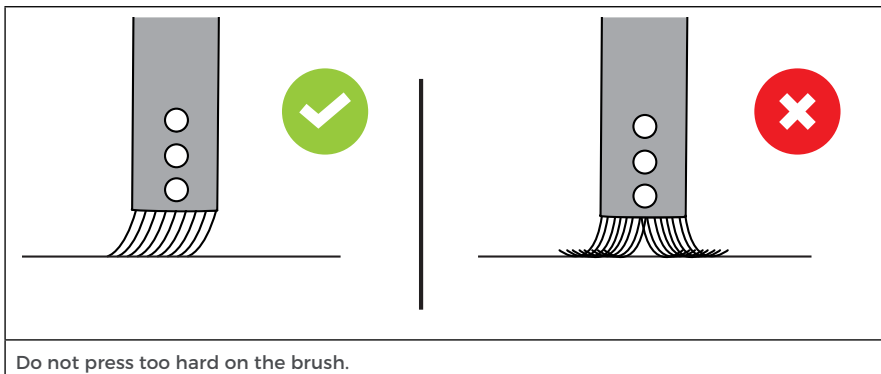

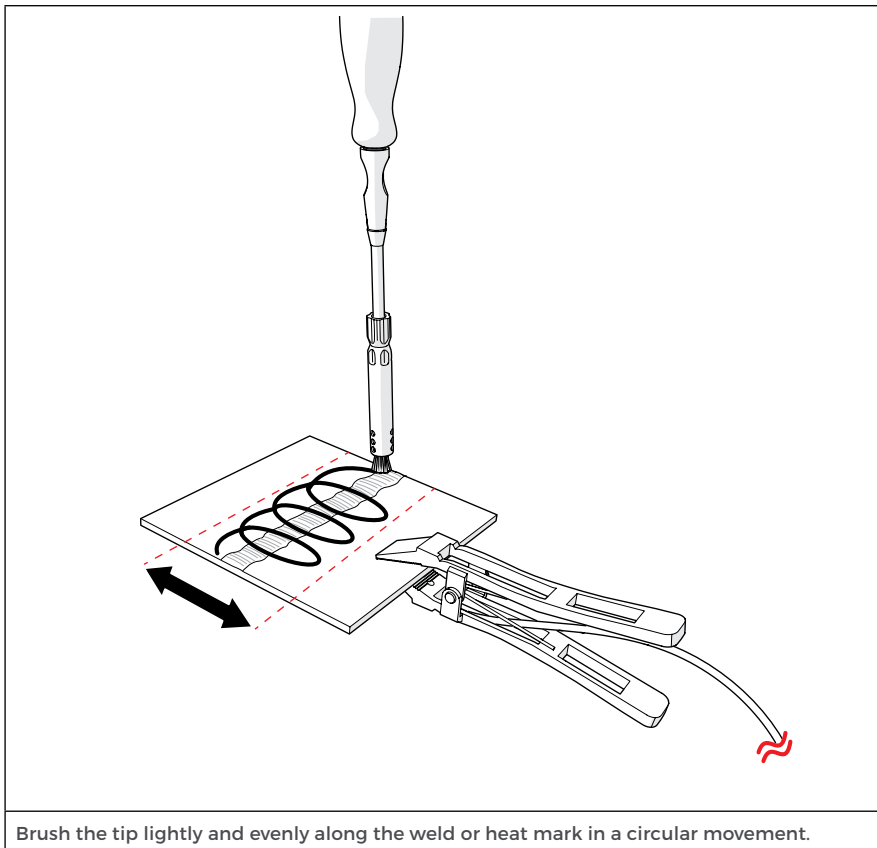

- The WELDBRUSH 700 produces an electric current which generates small sparks between the brush and the metal, this is normal.
- Make sure the brush is kept wet with the cleaning fluid at all times. This can be done by regularly dipping the brush in the cleaning fluid. This also helps to remove the dislodged oxides from the brush, to pick up fresh cleaning fluid and cool down the brush.
- Use the damp cleaning cloth to remove the residual fluid of the just treated surface carefully, so the fluid is not spread over a wide area of the surface.
- Repeat the brushing motion if necessary. Again, remove the residual fluid with the damp cleaning cloth.
- If the desired result is achieved, spray neutralizing fluid on the surface to clean and neutralize.

- Clean and dry the surface with the clean and dry neutralizing cloth or soft paper towel.
- After use, remove the brush from the wand and rinse in water. Keep dry in the storage box.

6.3 MARKING

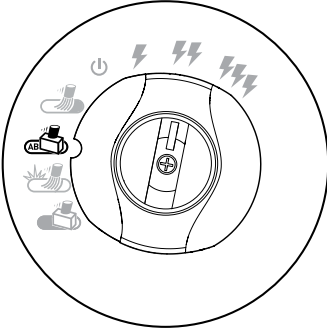

Marking leaves a permanent design on a metal surface with the use of a stencil. This process uses oxidation on the metal surface and does not apply color particles. The mark is permanent and forgery-proof.

A stencil can be ordered or printed with a stencil printer.

► **Follow these instructions:**

- Make sure the surface you want to mark is clean, degreased and dry. If needed remove any rust, paint, scale or other impurities.
- Pour marking fluid into the fluid container.
- Fill the spray bottle with neutralizing fluid.
- Connect the handle to the red cable. Push in firmly, and rotate clockwise until fastened.

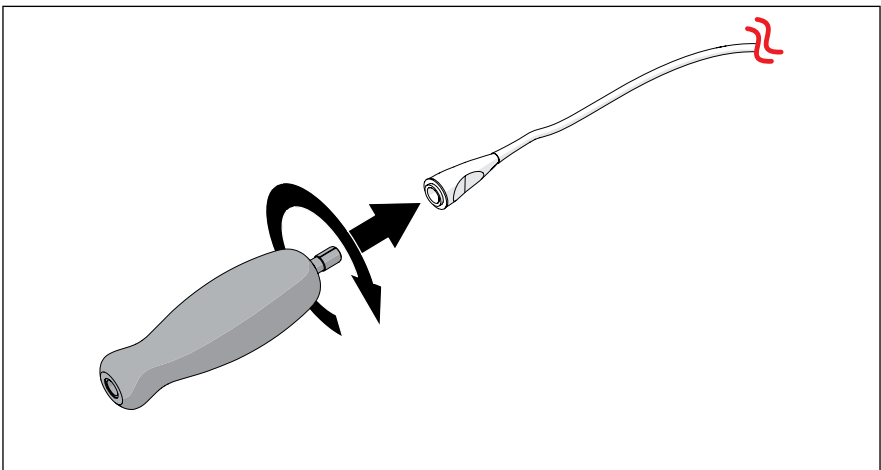

Connect the handle to the red cable

- Connect the electrode adapter to the handle.

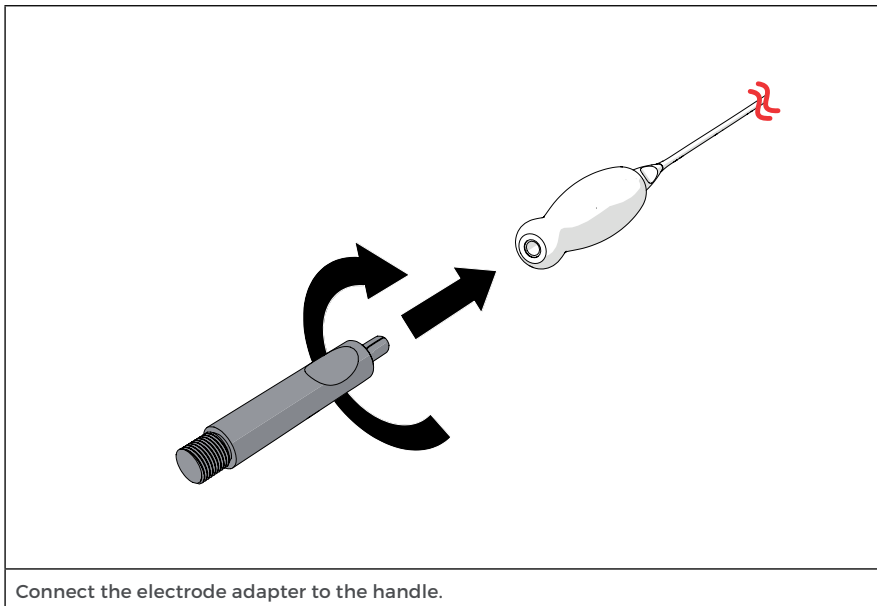

- Connect the marking electrode to the electrode adapter.

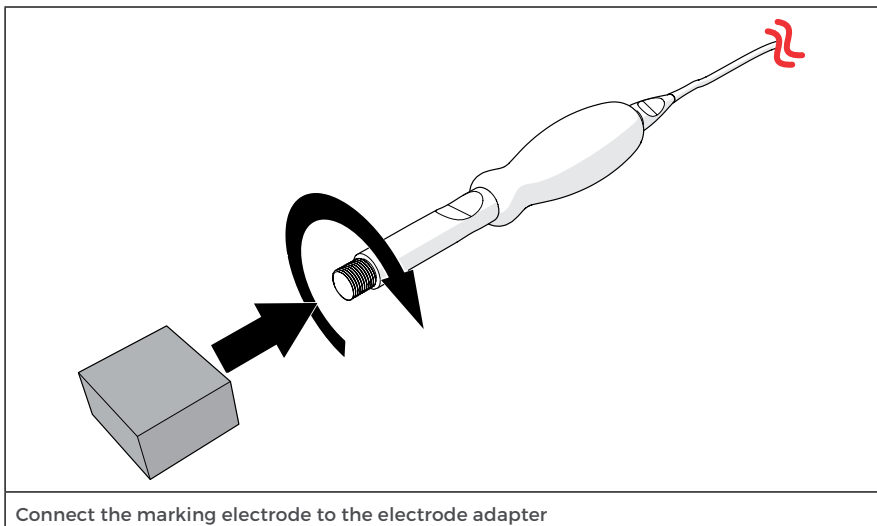

- Place the felt on the marking electrode. Use an O-ring to secure the felt.

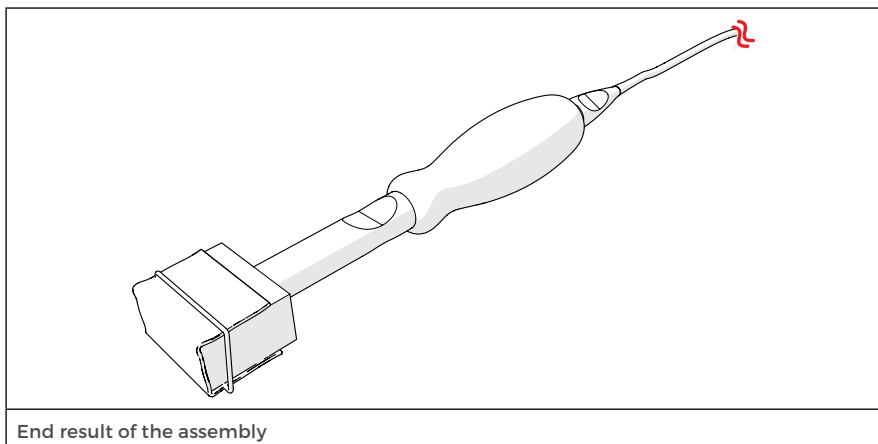
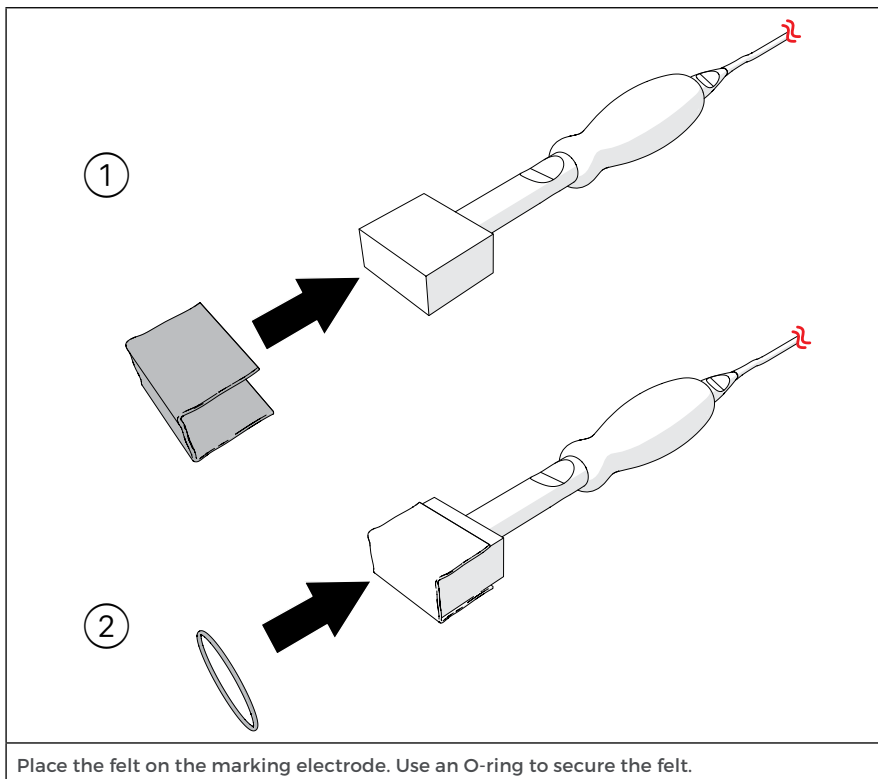

- Attach the earth clamp to a clean and dry area on the metal surface of the workpiece to be marked. If needed remove any rust, paint, scale or other impurities.

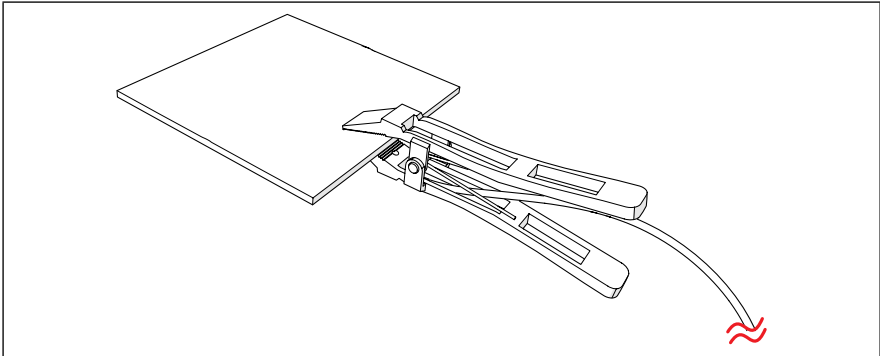

Attach the earth clamp to a clean area of the metal surface

- Switch the WELDRUSH 700 unit from “0” to “1”. This switch is located at the rear of the WELDRUSH 700 unit.

⚠ CAUTION

- *Make sure the power setting is switched to Stand-by.*
- Select the marking mode by turning the mode setting switch.

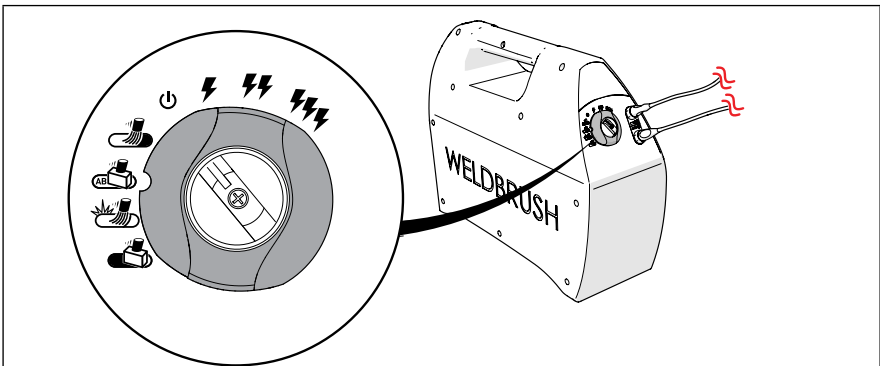

Select the marking mode

- Dip the marking electrode into the marking fluid so the felt is fully saturated, and allow the excess fluid to drip off before removing it from the fluid container.

- Wet the surface to be marked with marking fluid.
- Make sure the stencil is clean.
- Place the stencil in the desired position on the surface. If necessary, use removable tape to keep the stencil in the right position.

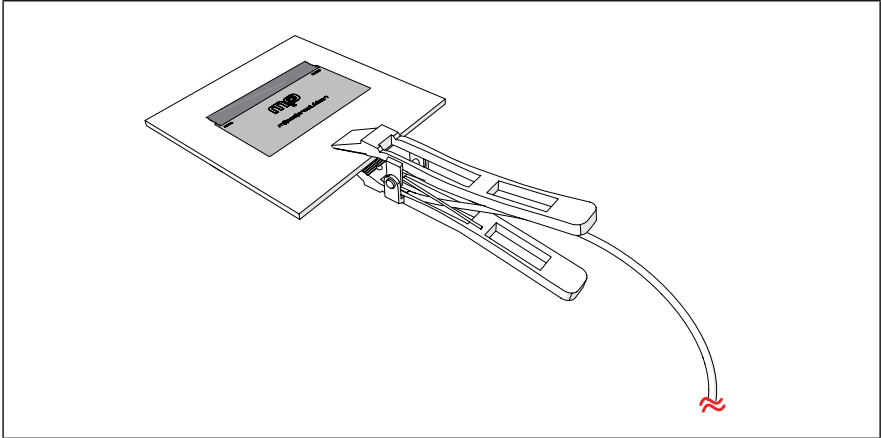

Place the stencil in the desired position on the surface.

- Select the power level by turning the power setting switch. We recommend to start by choosing power level 1, if confident with this process power setting 2 can be applied. Power setting 3 can be used but will quickly heat up the stencil and surface. Caution, in power level 2 and 3 the heat can damage your stencil.

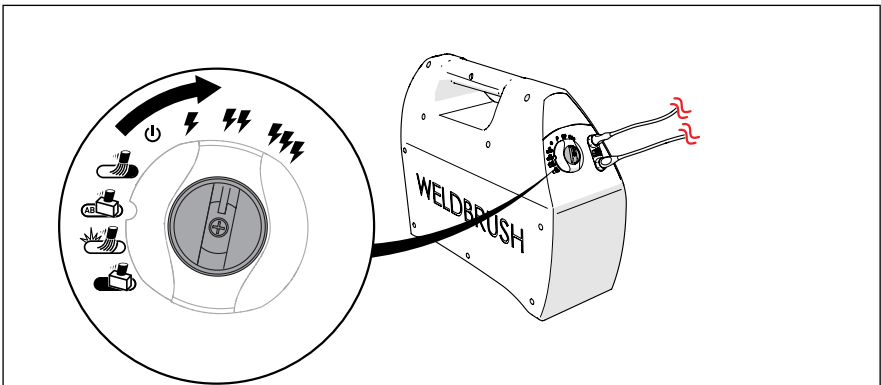

Select the power level

► **Read the following warnings and tips before you start marking:**

 **CAUTION**

- *Never make contact between the marking electrode and the surface without the felt, this will cause damage to the workpiece.*
- *Do not keep the electrode on the same place for too long, this causes the surface to get very hot and may cause damage or to the stencil.*
- *If the WELDBRUSH 700 is not operating correctly, please refer to the trouble shooting guide before contacting the WELDBRUSH 700 manufacturer or authorized distributor*

NOTICE

- *Do not apply the marking electrode on the metal surface without a stencil or touch the surface around the stencil with the marking electrode.*
- *Do not allow the stencil to become too warm as this could lead to premature wear and tear.*
- *Dark, i.e. dirty felts must be changed frequently.*
- *The felt will wear and need replacing before the risk of the electrode making contact with the workpiece.*
- *Do not re-use the felt for another mode except marking. The residual fluids in the felt can cause undesired surface discoloration in other modes.*

► **Now to start marking:**

- *Dip the marking electrode into the marking fluid so that the felt is fully saturated, and allow the excess fluid to drip off before removing it from the fluid container.*
- *With your other hand keep the stencil straight, tight and flat to the surface.*

- Move the marking electrode very evenly, with light pressure and in a zigzag or circular movement over the stencil.

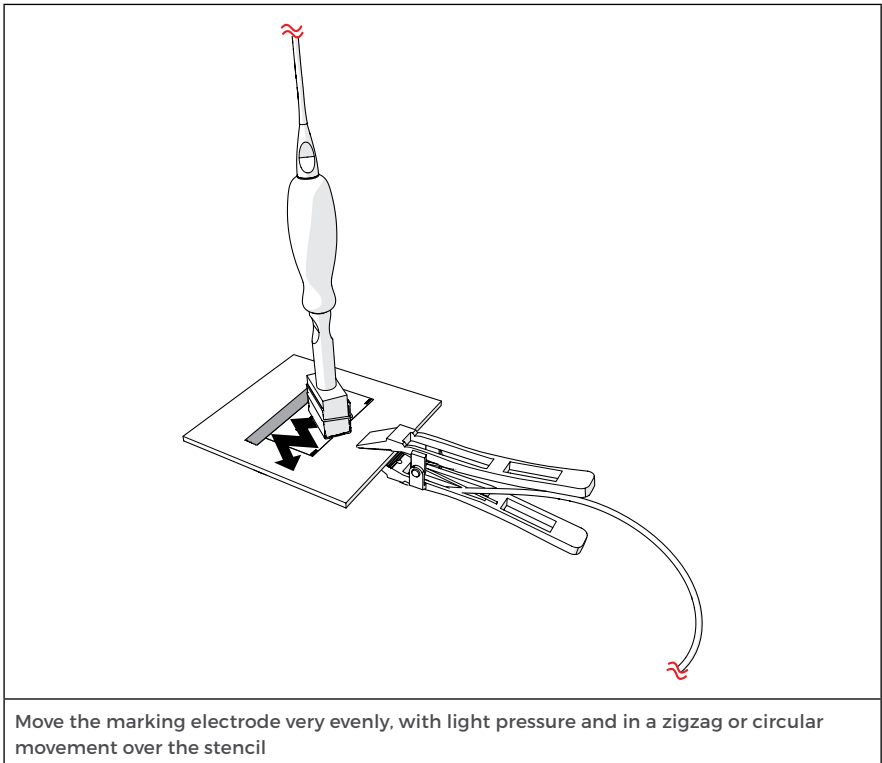

- Make sure the felt is kept wet with the marking fluid at all times. This can be done by regularly dipping the marking electrode in the marking fluid, and also to remove the dislodged oxides from the felt and to pick up fresh marking fluid.
- Check the surface you just treated and repeat the motion until the desired result has been reached.
- The result should be very sharp black marking, if not fully black repeat the motion or use a higher power setting. If the marking has a rusty color, the motion has been done too slowly.
- Remove the stencil.
- Use the wet cleaning cloth to remove the residual fluid of the surface carefully, so the fluid is not spread over the surface.
- Spray neutralizing fluid on the surface to clean and neutralize.

- Clean and dry the surface with the clean and dry neutralizing cloth or soft paper towel.
- After use, rinse the stencil very carefully with water and store in a safe place.

⚠ CAUTION

- *Do not re-use the felt for another mode except marking, residue of the fluids in the felt can cause undesired surface discoloration in other modes.*

6.4 ELECTRO-POLISH

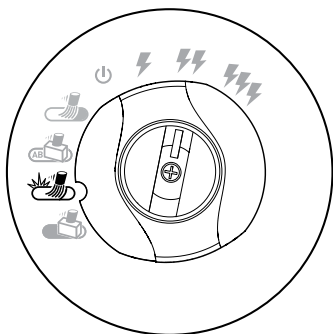

This mode will produce a bright metal surface. Previously cleaned welds can be polished or the gloss level adjusted to the surrounding surface as required. Matte areas after cleaning on either side of the weld is a result of chromium depletion during the welding process, these can be removed with this mode. Because this process removes iron but not the other components of stainless steel, electro-polishing vastly improves the corrosion resistance of the surface of the stainless steel.

► **Follow these instructions:**

- Pour electro-polishing fluid into the fluid container.
- Wet the cleaning cloth with water and wring out sufficiently.
- Fill the spray bottle with neutralizing fluid.

- Connect the handle to the red cable. Push in firmly, and rotate clockwise until fastened.

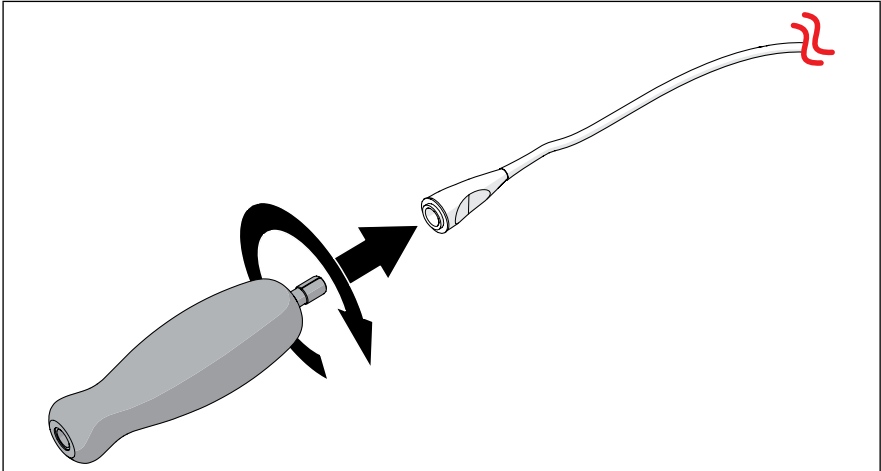

Connect the handle to the red cable

- Ensure the insulation on the wand is undamaged and in good condition.
- Connect the wand to the handle. Push in firmly, and rotate clockwise until fastened.

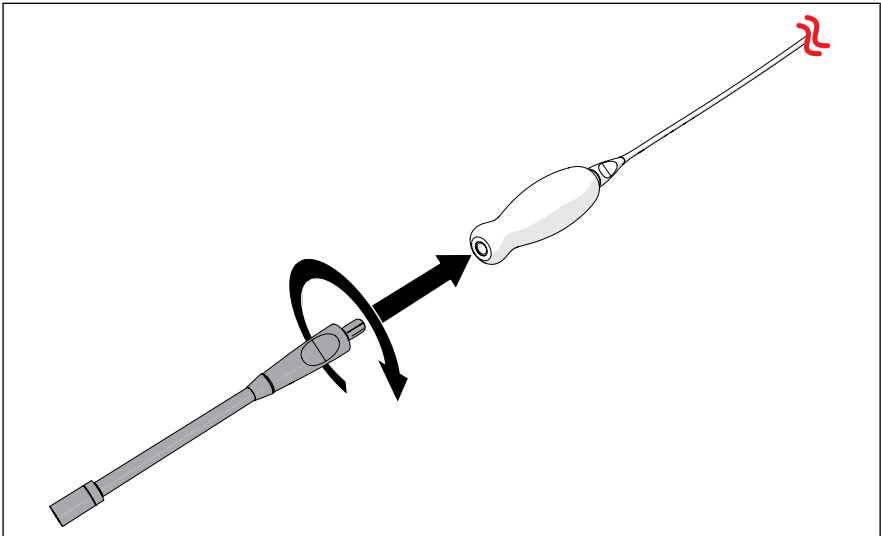

Connect the wand to the handle

- Place the sliding shroud over the wand.

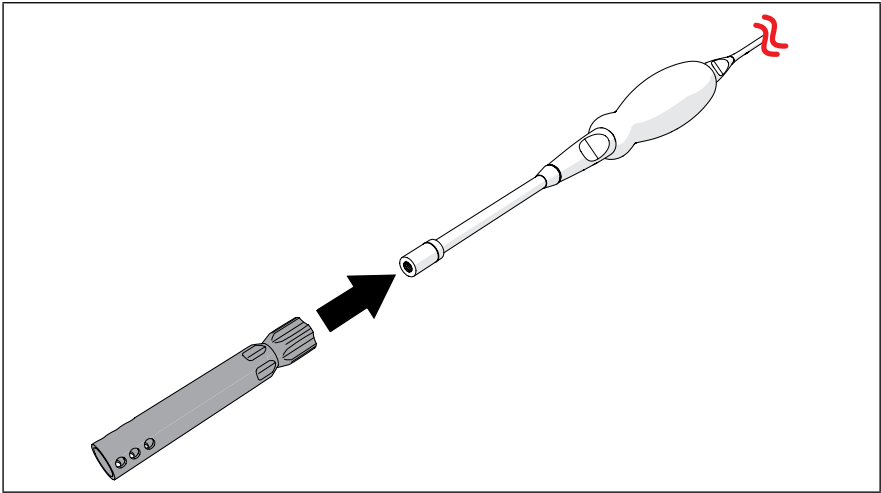

Place the sliding shroud over the wand

- Connect the brush to the wand. Turn clockwise until thread is fastened. Use a little copper fat in order to improve the electrical conductivity and protect the connection / thread from the fluids and avoid ceasing.

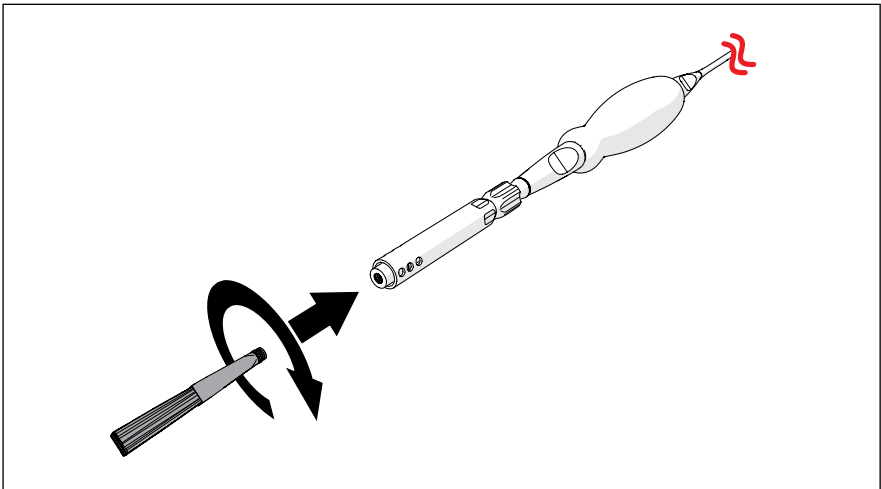

Connect the brush to the wand

- Slide down the sliding shroud which will concentrate the brush fibers. This increases the cleaning power over a smaller area. It will also cause the fibers to penetrate into pores and pits in the surface as small as 20 - 30 micron wide.
- When you slide up the sliding shroud, the brush fibers will spread. This will allow you to cover a wider area.

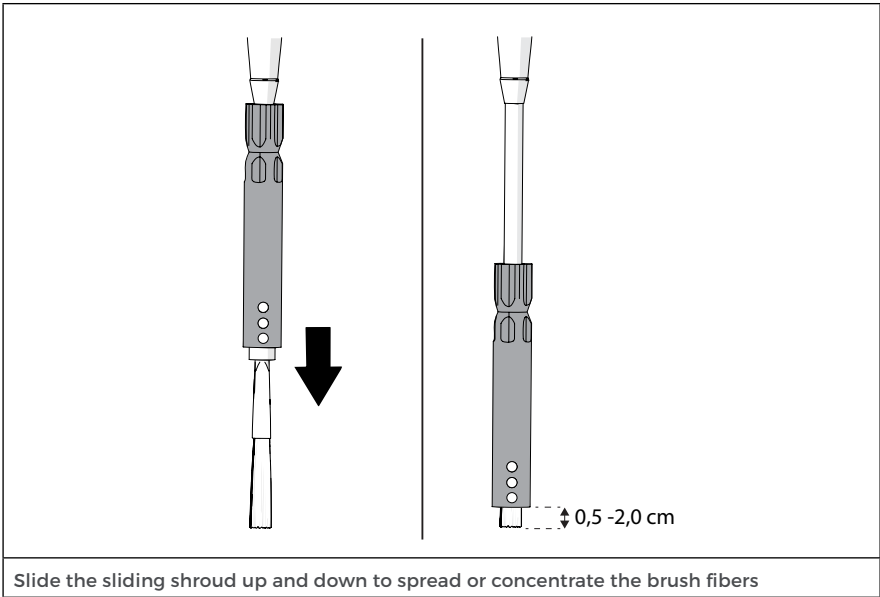
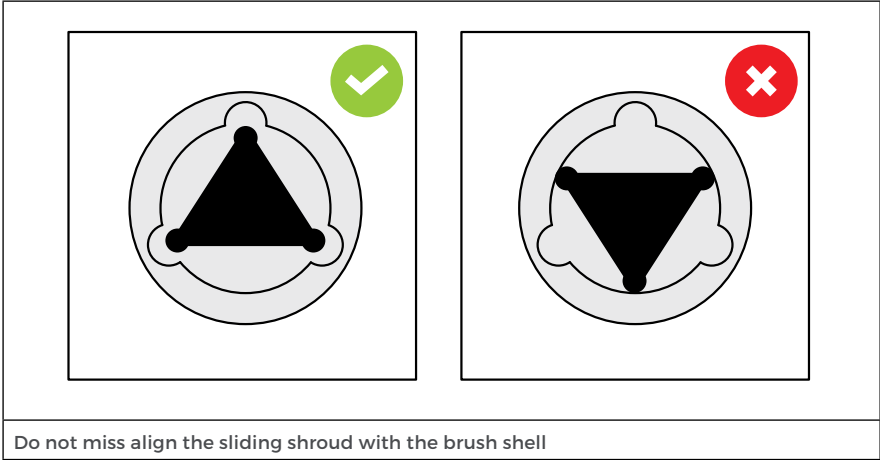

- Attach the earth clamp to a clean and dry area on the metal surface of the workpiece. If needed remove any rust, paint, scale or other impurities.

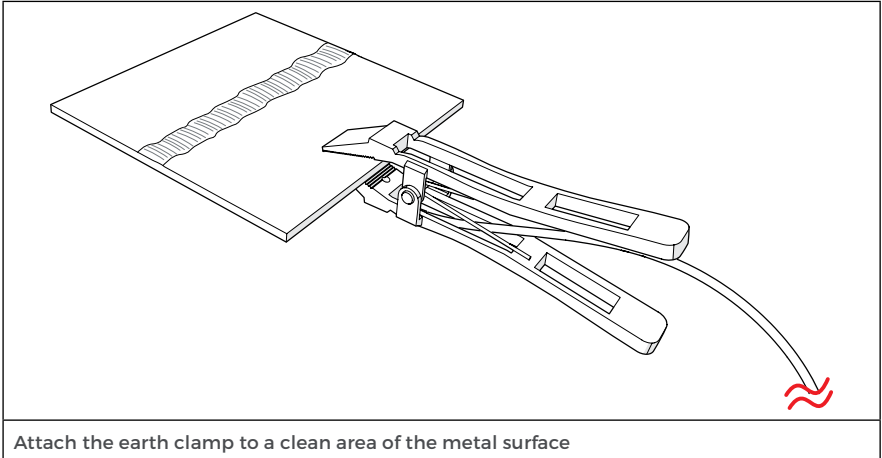

- Switch the WELDRUSH 700 unit from “0” to “1”. This switch is located at the rear of the WELDRUSH 700 unit.
- Select the electro-polishing mode by turning the mode setting switch.

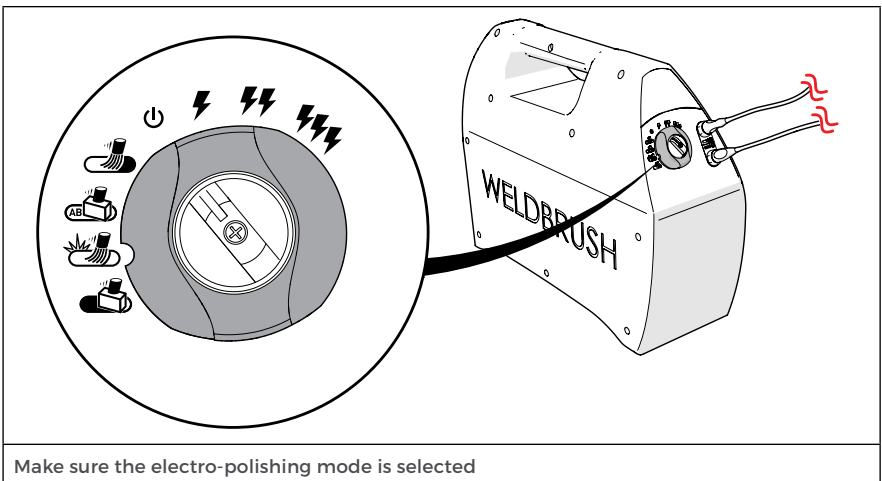

- Select the power level by turning the power setting switch. Power level 1 is the lowest power setting and power level 3 is the highest power level setting.

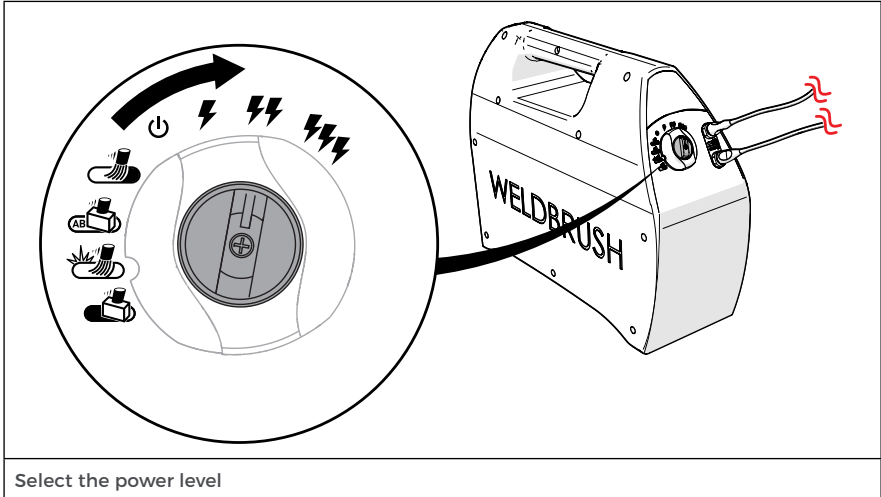

► **Read the following warnings and tips before you start electro-polishing:**

⚠ CAUTION

- *Be careful when electro-polishing welds and surfaces that are hot, this can cause damage or excessive wear to the brush and fluid.*
- *Do not keep the brush on the same place for too long, this causes the surface to get very hot and may cause surface damage or burn marks and excessive wear to the brush and fluid.*
- *If the WELDRUSH 700 is not operating correctly, please refer to the trouble shooting guide before contacting the WELDRUSH 700 manufacturer or distributor*
- *Do not slide the sliding shroud back far enough that it exposes the shell of the brush, this could make contact and cause damage to the workpiece as well as cause damage to the WELDRUSH 700.*

NOTICE

- *Electro-polishing will take about twice the time of cleaning & passivation, this means do the motion slower and use a little more fluid.*
- *Apply only sufficient pressure on the brush that the power moderator LED flashes only occasionally.*

- *By reducing or adding pressure to the brush, the operator can control optimal power.*
- *The brush will wear down with use and need replacing before it reaches the shell of the brush.*
- *Black marks as a result of excessive temperature during welding or due to lack of gas cannot be removed completely as these oxides are no longer metallic and electrically conductive.*
- *Matt areas after cleaning on either side of the weld result from chromium depletion from the welding process, these can be removed with the electro-polish mode.*

► **Now to start electro-polishing:**

- Dip the full length of the fibers of the brush into the electro-polishing fluid so that these are fully saturated, and allow the excess fluid to drip off before removing it from the fluid container.

NOTICE

- *The holes on the side of the shroud allow fluid to soak into the brush even when the shroud is covering the length of the brush.*
- With your other hand, hold the damp cleaning cloth.
- Brush the tip lightly and evenly on the weld or surface in a circular movement.

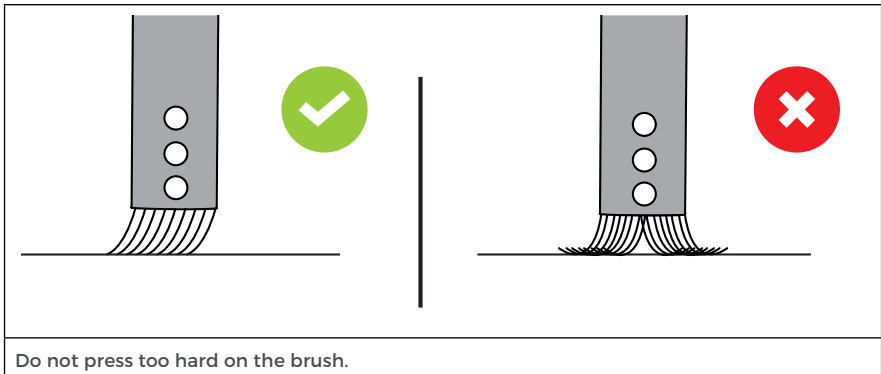

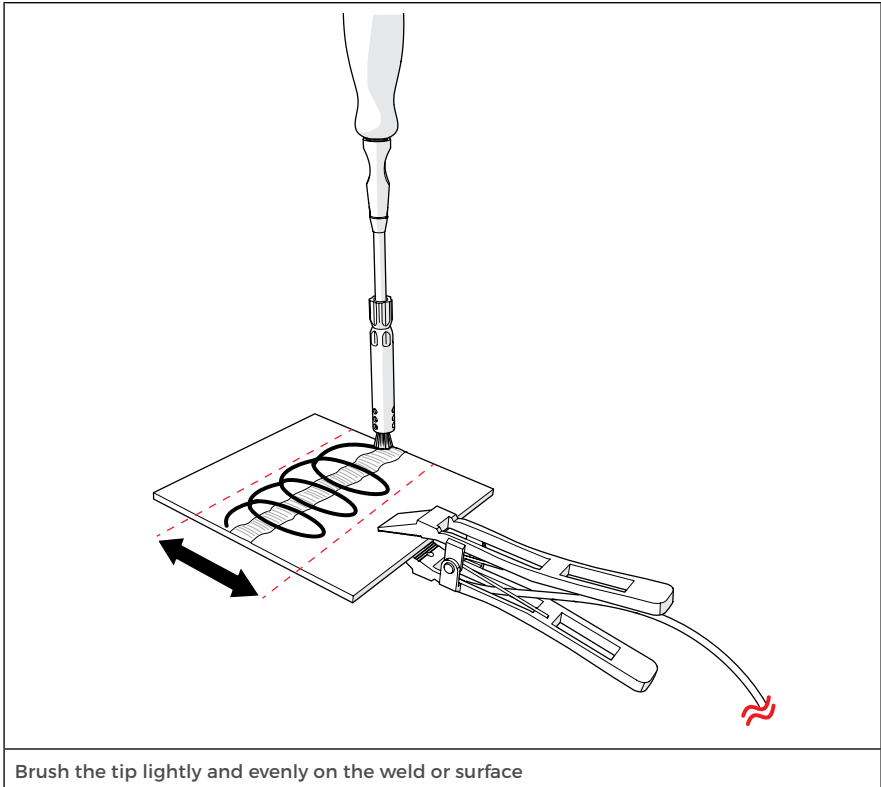

- The WELDBRUSH 700 produces an electric current which generates small sparks between the brush and the metal, this is normal.
- Make sure the brush is kept wet with the cleaning fluid at all times. This can be done by regularly dipping the brush in the electro-polishing fluid. This also helps to remove the dislodged oxides from the brush, to pick up fresh cleaning fluid and cool down the brush.
- Use the damp cleaning cloth to remove the residual fluid of the just treated surface carefully, so the fluid is not spread over a wide area of the surface.
- Repeat the brushing motion if necessary. Again, remove the residual fluid with the damp cleaning cloth.
- If the desired result is achieved, spray neutralizing fluid on the surface to clean and neutralize.
- Clean and dry the surface with the clean and dry neutralizing cloth or soft paper towel.
- After use, remove the brush from the wand and rinse in water. Keep dry in the storage box.

6.5 ELECTRO-PLATING

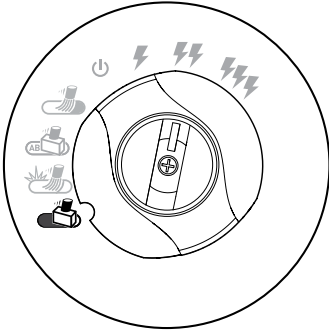

Electro-plating is a surface covering in which a metal is deposited on a conductive surface and is used to decorate objects, for corrosion inhibition, to improve solderability, to harden, to improve wearability, to reduce friction, to improve paint adhesion, to alter conductivity, to improve IR reflectivity, for radiation shielding, and for other purposes.

► **Follow these instructions:**

- Make sure the surface you want to electro-plate is clean, degreased and dry. If needed remove any rust, paint, scale or other impurities.
- Pour plating fluid into the fluid container.
- Fill the spray bottle with neutralizing fluid.
- Connect the handle to the red cable. Push in firmly, and rotate clockwise until fastened.

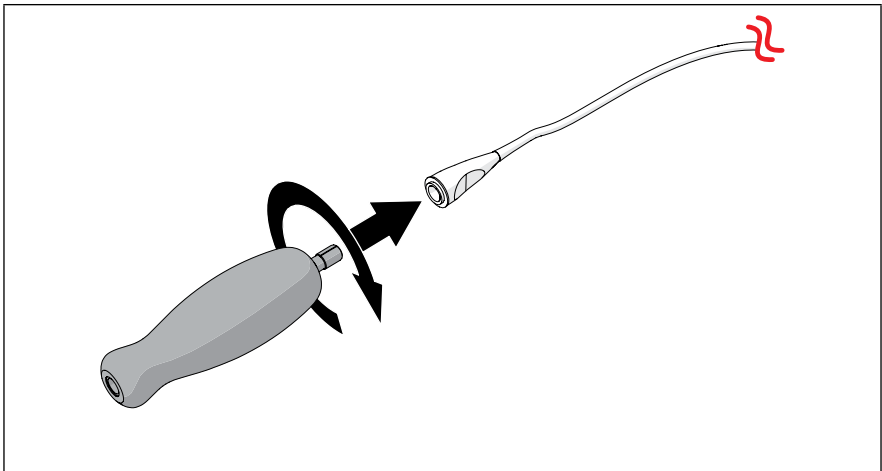

Connect the handle to the red cable

- Connect the electrode adapter to the handle.

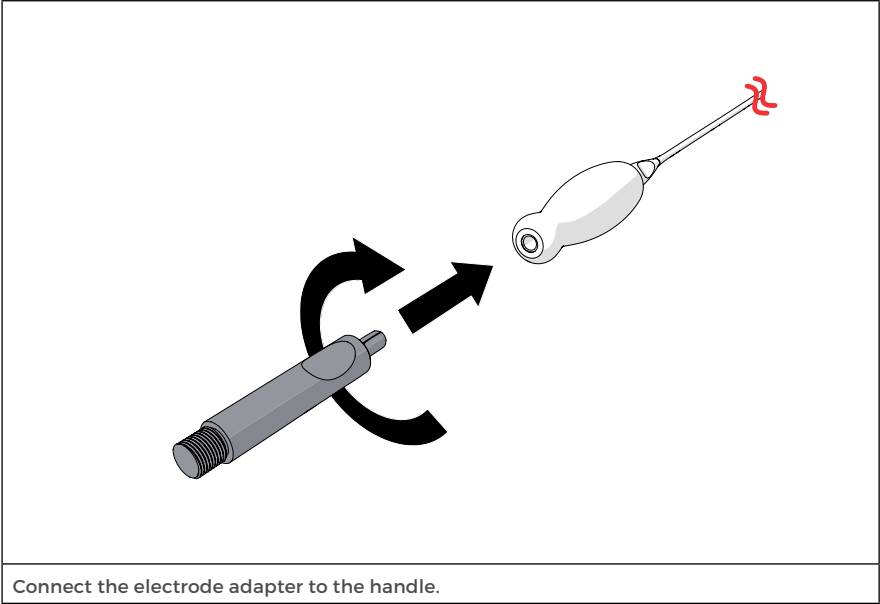

- Connect the plating electrode to the electrode adapter. Ensure you are using the right electrode for the preferred plating mode.

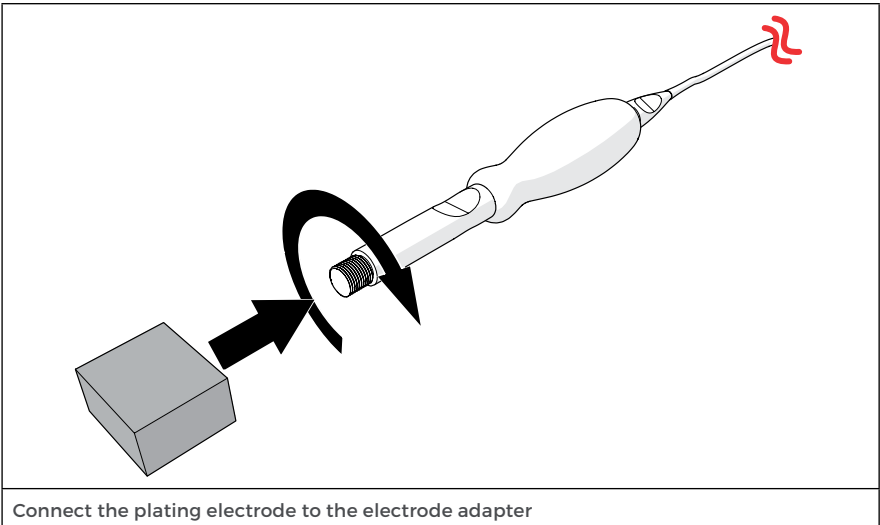

- Place the felt on the plating electrode. Use an O-ring to secure the felt.

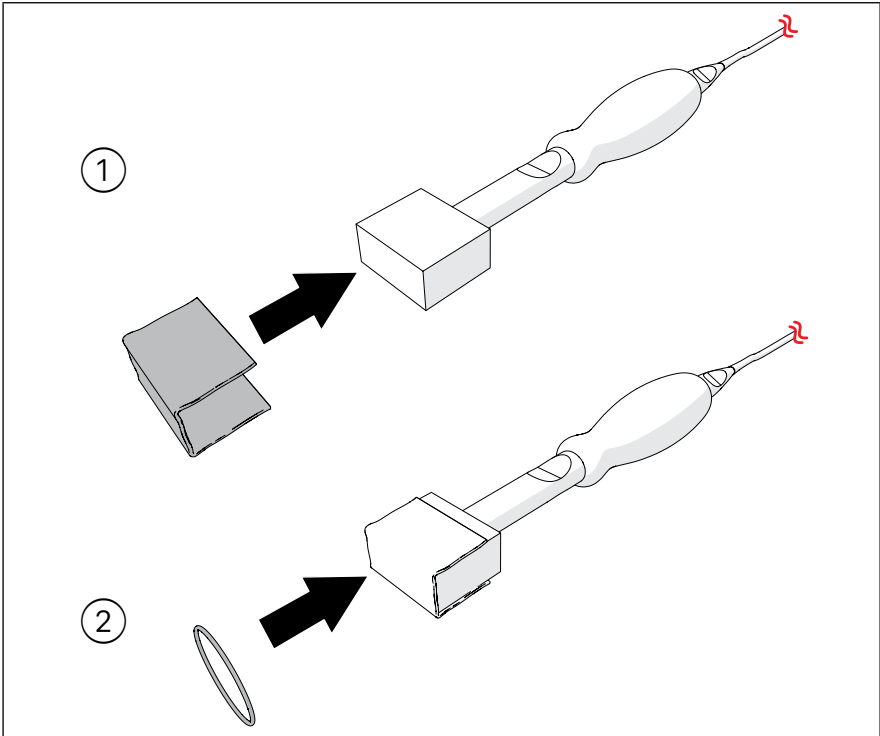

Place the felt on the plating electrode. Use an O-ring to secure the felt.

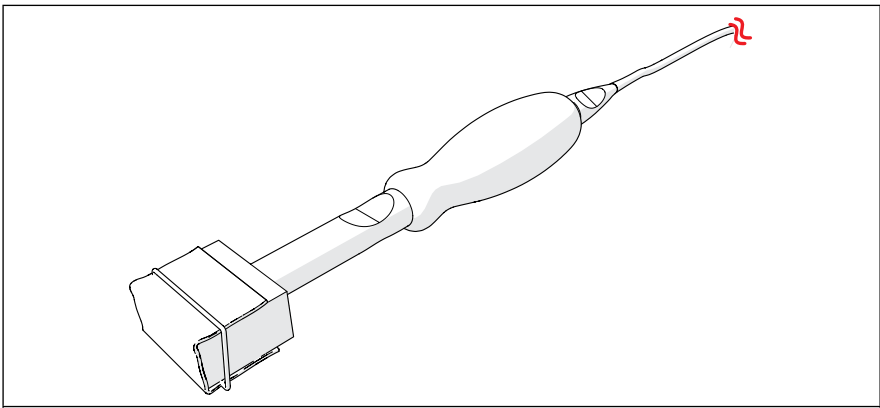

End result of the assembly

- Attach the earth clamp to a clean and dry area on the metal surface of the workpiece to be electro-plated. If needed remove any rust, paint, scale or other impurities.

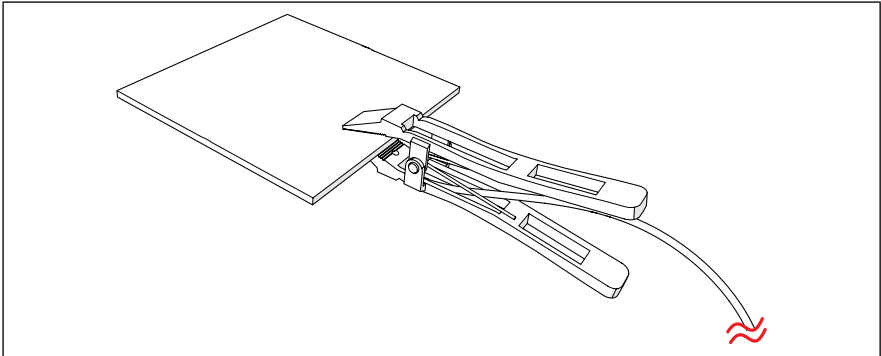

Attach the earth clamp to a clean area of the metal surface

- Switch the WELDBRUSH 700 unit from “0” to “1”. This switch is located at the rear of the WELDBRUSH 700 unit.
- Select the electro-plating mode by turning the mode setting switch.

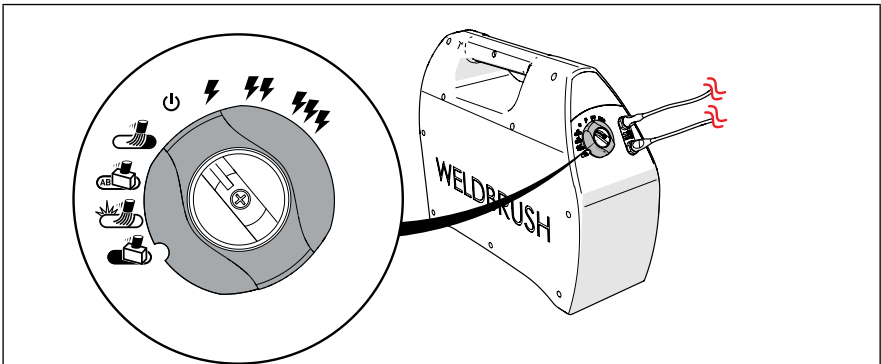

Select the plating mode

- Select the power level by turning the power setting switch. Power level 1 is the lowest power setting and power level 3 is the highest power level setting. Start by using power setting 1, if confident power setting 2 or 3 could be applicable.

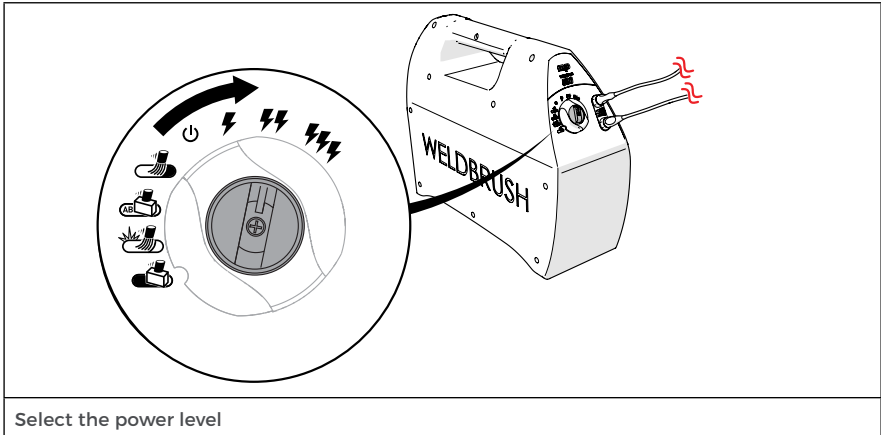

► **Read the following warnings and tips before you start plating:**

⚠ CAUTION

- *Never make contact between the plating electrode and the surface without the felt, this will cause damage to the workpiece.*
- *Do not keep the electrode on the same place for too long, this causes the surface to get very hot and may cause damage.*
- *If the WELDRUSH 700 is not operating correctly, please refer to the trouble shooting guide before contacting the WELDRUSH 700 manufacturer or distributor.*

NOTICE

- *Dark, i.e. dirty felts must be changed frequently.*
- *Electro-plating works best on electro-polished surfaces.*
- *The felt will wear and need replacing before the risk of the electrode making contact with the workpiece.*

► **Now to start electro-plating:**

- Dip the plating electrode into the electro-plating fluid so that the felt is fully saturated, and allow the excess fluid to drip off before removing it from the fluid container.
- Move the electrode very evenly, with light pressure and in a circular movement over the surface.

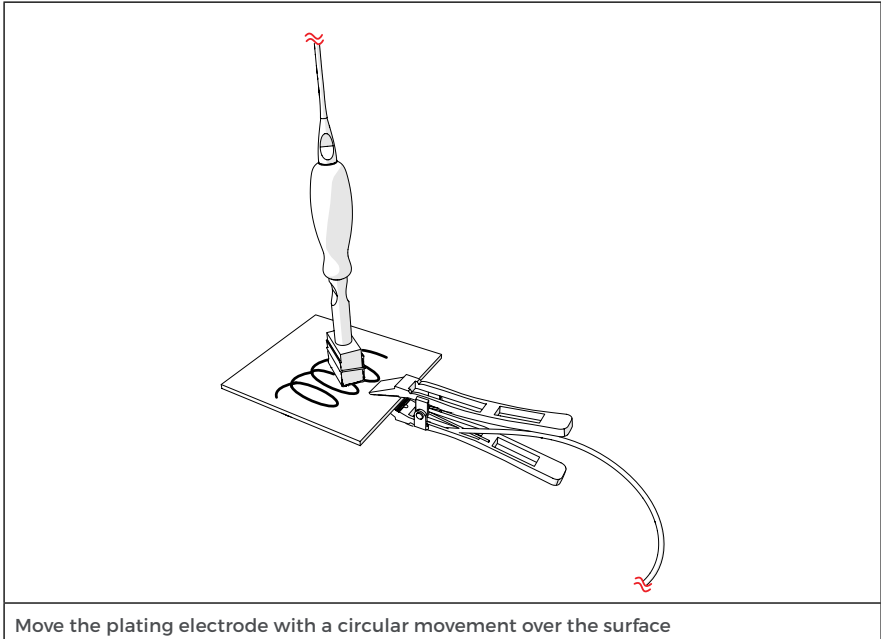

- Make sure the felt is kept wet with the plating fluid at all times. This can be done by regularly dipping the plating electrode in the plating fluid, and also to remove the dislodged oxides from the felt and to pick up fresh plating fluid.
- Check the surface you just treated and repeat the motion until the desired result has been reached.
- The result should be an even plated surface.
- Use the wet cleaning cloth to remove the residual fluid of the surface carefully, so the fluid is not spread over the surface.
- Spray neutralizing fluid on the surface to clean and neutralize.
- Clean and dry the surface with the clean and dry neutralizing cloth or soft paper towel.

7 AFTER OPERATION

- Clean the unit, connections of the handle and the earth clamp after use with water. Keep the unit and all its parts and accessories clean and dry.
- Make sure that all the equipment is carefully packed and the fluid containers are closed firmly.
- Fluids should be kept in a dark and cool place, protected from direct sunlight.

8 MAINTENANCE

- Maintenance may only be carried out by an authorized person. Before beginning maintenance, inspection or repairs, switch off the unit and secure against inadvertent switching on by disconnecting the unit from the mains power.
- Without the prior consent of the manufacturer, no opening of the unit, alterations, additions or removals of any sort may be made on the unit. Only genuine spare or replacement parts originating from the manufacturer or an authorized dealer may be used.
- Keep the connection between the brush and wand lubricated with copper fat in order to improve the electrical conductivity and protect the connection / thread from the fluids and avoid ceasing.
- Repair work to the unit may only be carried out by certified and agreed companies.

9 ENVIRONMENT AND DISPOSAL



The symbol on the product, the accessories or packaging indicates that this product must not be treated as household waste. Dispose of the product via a collection point for the recycling of waste electrical and electronic equipment within the EU and in other European countries that operate separate collection systems for waste electrical and electronic

equipment. By disposing of the product in the proper manner, you help to avoid possible hazards for the environment and public health that could otherwise be caused by improper treatment of waste equipment. The recycling of materials contributes to the conservation of natural resources. Therefore do not dispose of your old electrical and electronic equipment with the household waste.

Do not discharge contaminated undiluted fluids to the sewerage system or environment. The contaminated fluid can contain heavy metal residues dislodged from oxidized welds and metal surfaces, which must be filtered and disposed of in a proper manner.

Contact your local authority for specific regulations in your area.

10 TROUBLE SHOOTING

Make sure before referring to this troubleshooting, all instructions and recommendations in this manual are fully read, understood and applied. If the WELDBRUSH 700 unit doesn't work or is slower than usual, please check the following:

1. Is the LED on the front panel illuminated? If not, check if the mains power cable is damaged and make sure the WELDBRUSH 700 unit is switched from "0" to "1". This switch is located at the rear of the WELDBRUSH 700 unit. If the LED still does not illuminate, please contact the manufacturer or the authorized dealer.
2. Check if the red and black sockets on the WELDBRUSH 700 unit are clean. This can be done by disconnecting the red and black cables.
3. Disconnect all parts from the cables and check if any of these are damaged.
4. Check if all connections of all parts connected to the cables are clean, especially the connections between the brush and the wand. In case there is corrosion or other impurities on the connections, clean these carefully under water with a wire brush or soft abrasive. Assemble all parts and check if it works. Alternatively also try with a new brush.
5. Check if the earth clamp is connected to a conductive point.

NOTICE

The most common reason for 'no power' is due to a poor connection. Good conductivity is very important for this process to be effective. This problem is mostly caused by dried up fluid between the connection of the brush to the wand. This connection can be cleaned carefully under water with a wire brush or soft abrasive.

If all of the above does not solve the problem contact your authorized dealer.

11 WARRANTY INFORMATION

This warranty applies to any defects that appears within 24 months from the date of invoice. To claim under this warranty, the defects must be notified within two weeks of their appearance to your authorized dealer that will give you the suitable repair procedure. If needed, you will need to return the goods together with all accessories and parts at the expense of the owner for a full assessment and report.

Additional limitations, exclusions and requirements.

This warranty does not extend to:

- Consumables used with the WELDBRUSH 700
- Any defects caused by normal wear and tear or incidental or inconsequential damage
- Any defect caused by misuse, negligence or other abuse of the goods
- Any defect caused by accidents or alterations
- Goods that have not been cleaned and maintained in accordance with the user's manual available for the WELDBRUSH 700
- Impact, from dropping or hitting the unit or it's parts.
- Loss or damage, including consequential loss or damage, to your work or facilities arising out of or in connection with the use of the WELDBRUSH 700
- Unless otherwise expressly stated, any right to be reimbursed or compensated for physical or financial injury, loss, damage, expense, time or inconvenience (whether direct or indirect) arising out of the occurrence of the defect in the product or your inability to use the product.

12 EC – DECLARATION OF CONFORMITY

EC – Declaration of Conformity

In accordance with the EEC low-voltage directive 2006/95/EC (12 Dec 2006), and specifically, in accordance with Annex IV, we hereby certify that the following described machines, in their conception, construction, and form, put by us into circulation, are in accordance with all relevant essential health and safety requirements of the EC low-voltage directive as amended, and in accordance with the national laws and national regulations, that are based on this directive.

This declaration is no longer valid if the internal contents, or the case material of our machines, is modified without our consent, or if a unit is repaired with parts not approved for use by us.

Manufacturers name and address:

Weldbrush Pty Ltd
Unit 3, 8 Bromley Rd
Emu Heights, 2750
NSW, Australia
+61247357700

Description of the machines:

Function: Aluminium, Brass, Bronze, Copper and stainless steel, cleaner and polisher
Types/Models: WB500 Rev 7, WB500 Rev 5, WB400 Revision 2, WB400 revision 3,
WB700 Rev1, WB900 Rev1, WB450 Rev 2, and WB350, Rev2.

Year of Construction: 2014 onwards

Applicable Harmonised standards:

EN 61558-2-6 in particular to reinforced insulation
EN 61000-3-2 Class A

Location of documentation:

The Technical documentation required by Annex IV(3) of the Low Voltage Directive is maintained by:

Mijlpaal Produkten
Oud Camp 22
3155 DL MAASLAND
Netherlands

Personal Data of the Signer:

David leComte, Technical Director WeldBrush Pty Ltd

Signature:



Date 12.02.2016



SFS.

cleaning polishing passivation marking